



Digital, Serial & Printer

Multifunction Combo card with RS-232, Digital I/O & Centronics Port for Module & VMEbus Systems

The photograph shows the Serial and Digital I/O board for Module systems. It is also available as a VMEbus slave.

Features

- Two RS-232 buffered Serial ports
- Based on the 8530 chip
- LED signal monitoring
- Centronics parallel printer port
- Digital ports based on 8536 multi-function chip
- Four independent 8-bit I/O ports
- Two special purpose 4-bit I/O ports
- Six 16-bit counter/timers
- 5 Volt only operation
- Up to 4 boards per system
- 32-byte address space

Module Bus

- Compatible with Module products
 - Full software drivers and examples
 - Low cost target
 - Small size 100*118mm
- VMEbus Slave Rev C.1**
- 3U single height euro-card
 - 100*160mm

Description

This multi-function board extends the I/O facilities of the CPU by adding two RS-232 serial Ports, a Centronics printer port, 24 general purpose bi-directional digital lines, 4 special function digital lines and 6 counter/timers. Up to 4 boards can be used in any system.

The board requires a single 5 Volt supply. The serial ports use on board DC-DC convertors to provide the RS-232 output drive. RTS and CTS handshaking lines are also present with LED monitoring on all the serial lines. The 40 digital lines are provided by two 8536 counter/timer and parallel I/O devices. These include six 16-bit counter/timers together with a whole host of port configurations and inter-

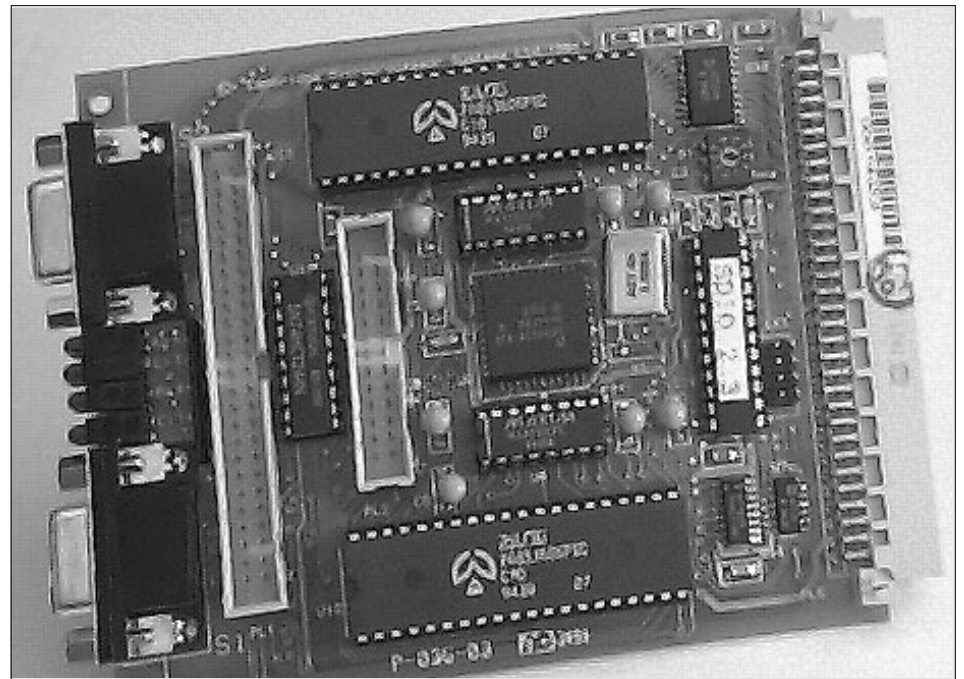

rupt sources. One of the digital ports is tracked out to a buffered Centronics 26 way IDC connector for driving parallel printers. The card is one from the range of 'Dual-Bus' cards. It can be supplied in standard single euro-card VMEbus form or as a two thirds euro-card size on 'Module Bus'. The 'Module Bus' is effectively the PROcessor bus with minimum bus buffering. It is compatible with the Module CPU range and becomes very cost effective when targeting small systems.

Serial Ports

The serial ports use the popular 8530 DUART. The data signals are buffered to RS-232 specification. On board DC-DC charge pumps convert the single 5 volt supply to 10 Volts necessary for the RS-232 output levels. The inputs will withstand up to 30 Volts. The outputs are short circuit protected. The number of data bits, the parity and the stop bits are all software selectable. The Baud rate can be from 75-19200 Baud. The chip supports break detection and generation and will check parity, overrun and framing

errors. The chip also supports SDLC and HDLC protocols. Each channel can be independently programmed.

Digital I/O

The digital channels are based on two 8536 digital chips. These will satisfy nearly all digital I/O requirements for parallel I/O and counter/timers with a wealth of programmable facilities including edge detection and high speed parallel data handshaking. The six 16-bit counter timers can be used for pulse generation or input counting with 8 special purpose control lines.

Printer Port

The Centronics port uses one of the digital chips 8-bit ports via a CMOS buffer. This can be connected to any Centronics device of which the usual is the parallel printer port.

The Module Bus version of this card comes complete with all the necessary software drivers. For VMEbus users we would highly recommend access to the data sheets for the 8530 and 8536.

The drawing shows a block diagram of the Serial and Digital I/O board.

Specification

Serial Port

Data Bits Parity and stop bit control
 75-19200 Baud
 RS-232 buffered
 Receiver, Transmitter, CTS, RTS
 LED signal monitoring
 Bits per character 5,6,7 or 8
 Stop bits 1/2, 1 or 2
 Parity odd, even or non
 Break generation or detection
 Parity, overrun and framing error detection
 Input range - 30 to + 30 Volts
 Output drive 9 Volts into 3K Ohms
 4 Volts/uS slew rate min.
 Short circuit protected
 SDLC and HDLC protocols

Digital STE I/O

Four 8-bit parallel ports
 Two 4-bit special purpose ports
 Total of 40 digital lines
 Programmable
 Parity, direction
 1's latching inputs
 Open drain outputs
 Pattern recognition
 Handshaking

Counter/Timers

Six 6-bit registers
 Continuous/single cycle

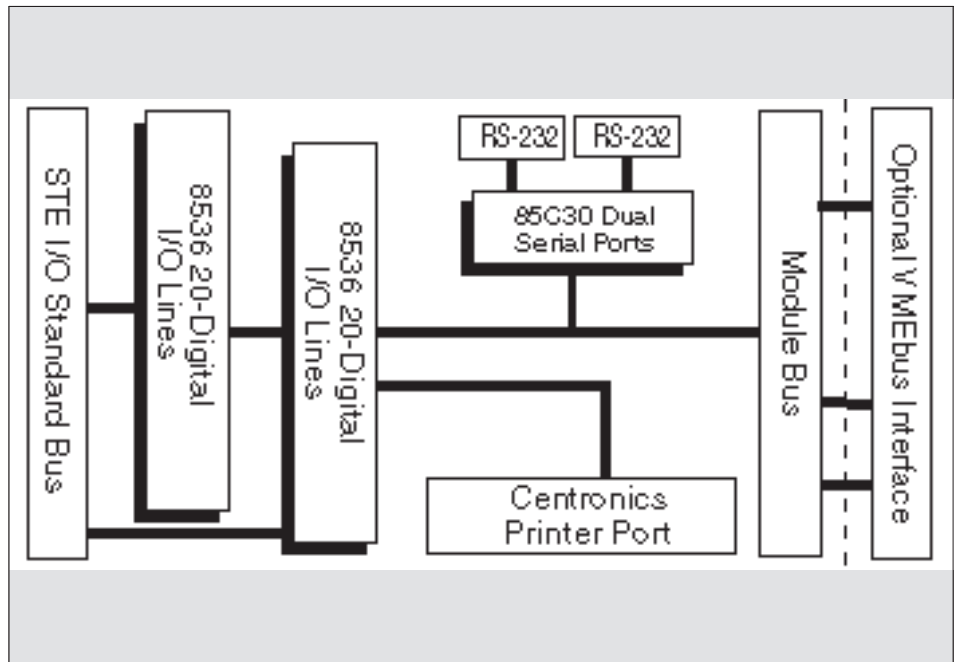

External output, count,
 Trigger, gate
 Retrigger/non-retrigger

Centronics Port

8-bit buffered plus strobe
 Ack and busy inputs

Module Bus

A14:D8 32-byte peripheral bus space
 Module Bus compatible
 Size 100 x 118 mm

VMEbus

A16:D8 32-byte short address space
 \$29, \$2D modifiers
 Interrupter IRQ(1-7)

Size 100 x 160 mm

Connectors

Serial female 9 pin D
 Digital 50 box IDC
 Centronics 26 way box IDC
 64 way PRObus_ DIN 41612
 or 96 way VMEbus DIN 41612

Power Consumption at 5 Volts

400mA K-600, 150mA K-602 typ.
 500mA D-600, 250mA D-602 typ.

Temperature Range

0 to 70 degC

Ordering information

Module Bus Version

| | |
|-------|-------------------------------|
| K-600 | Module Bus version |
| K-602 | Two Channel serial ports only |

VMEbus Version

| | |
|---------|-------------------------------|
| D-600 | VMEbus version |
| D-602 | Two Channel serial ports only |
| MDK-600 | Technical manual |

93-004 970307



Cambridge Microprocessor Systems Limited,

Unit 17 - 18 Zone 'D',
 Chelmsford Road Ind. Est.,
 Great Dunmow,
 Essex, U.K. CM6 1XG.

Telephone 01371 875644
 FAX 01371 876077

E-mail sales@cms.uk.com

Web site <http://www.cms.uk.com>

01371 875644



Cambridge Microprocessor Systems Ltd.