

## FM-600 *Embedded* CONTROLLER

42 Digital I/O  
18 Analogue I/O  
LCD & Keypad



The picture shows the FM-600P Controller with a 4 x 20 LCD and a number of custom keypads

### FEATURES

- 68000 Compatible Micro controller
- 14.7456 MHz operating speed
- 512 K-bytes of Flash EEPROM
- 512 K-bytes of Battery Backed Static RAM
- Three Serial Ports
- 2 RS-232, 1 RS-232 or RS-485
- Real Time Calendar Clock
- Software Watch dog
- Alphanumeric/Graphic LCD Port
- 64 Key Matrix Keypad Port
- Standard Eurocard size 100 x 160mm
- 5 Volt only operation
- Many low power modes
- Typical current, < 250mA
- Module Bus expansion
- M-Bus (I<sup>2</sup>C bus)
- 42 TTL/CMOS digital I/O channels
- 8 13-bit Analogue Inputs
- 8 8-bit Analogue Inputs
- 2 8-bit Analogue Outputs
- 2 16-bit timer/counters
- Minos Real Time Multitasking Operating System
- Program in Modula-2, 'C' or Assembler

### DESCRIPTION

The FlashModule FM-600 is the top of the range controller in our low cost FlashModule range typically, £195 in quantity. In common with all controllers in the range it has a powerful 16-bit 68000 based controller, three serial ports, 512 K-bytes of Flash EEPROM, 512 K-bytes of static RAM and a Real Time Calendar Clock. In addition to these standard features, the FM-600 has eight channels of 12-bit analogue input, eight channels of 8-bit analogue input, 2 channels of 8-bit analogue output, a matrix keypad port and an alphanumeric liquid crystal display port with options for a range of graphics panels. Code that is written for this controller can also be used with no modification on any other controllers in this range, allowing the user to choose the controller most suitable for a particular application without having to rewrite the code each time.

The three serial ports can be configured to operate over a wide range of formats. By default the terminal serial port (S1) is configured to operate at 38400 baud with a data format of 8 bits, 1 stop bit and no parity. The other two serial ports default to 9600 baud with the same data format. One of the serial ports can be configured for networking operation (drivers and libraries provided as standard) and can operate with up to 253 slaves over a two wire half-duplex RS-485 interface in addition to the standard full duplex RS-232 interface provided by the other two serial ports. CTS/RTS handshaking is used as standard on all RS-232 serial ports. Baud rates can be configured from an application program in the range 300 to 38400 baud.

The Real Time Calendar Clock is fully year 2000 compliant and will keep track of the current time, day and date. It also has an alarm facility which can interrupt the processor at a given time and date. A battery retains the data in the real time clock when the board is not powered. The device used is interfaced to the main processor using the M-Bus. Its own on board oscillator drives the clock for accurate time keeping.

On board static RAM is battery backed to prevent data loss during power down. The control signals are disabled to prevent erroneous data being written into the RAM during the power down cycle. The 512 K-bytes of on board RAM can be expanded up to 8.5 M-bytes using static RAM on an expansion card. When used with the our FlashModule RAM expansion cards the operating system detects how much RAM is available and configures the memory manager accord-

ingly at power up.

The 512 K-bytes of Flash EEPROM on the FlashModule can be user programmed using the utility programs provided with the Development or Starter Packs. The Flash memory can be programmed using a single 5 Volt supply removing any requirements for high voltage supplies. The Flash memory is divided up into eight blocks each of 64 K-bytes. Before data can be programmed into one of these blocks the whole block must be erased. When using the Minos operating system the first three blocks of the Flash memory are protected for system use and can not easily be erased or written to. The remaining

five blocks are designated user sectors and can be read or written as required. The utilities provided allow data to span block boundaries and a sector will only be erased if an area to be programmed contains data. Turnkey programs can be loaded into the Flash memory and run from power on. To allow these programs to be modified a switch is provided which gives access to the development environment. The on board Flash memory can be expanded up to 1 M-byte using an expansion card. As with the static RAM expansion when the CMS expansion cards are used the operating system will detect how much Flash or EPROM memory is available and configures the memory manager accordingly. The whole on board Flash memory can be erased and reprogrammed using the FlashFormatter card which contains a compatible Flash memory and a default boot EPROM to enable new programs or data to be uploaded. The FlashFormatter card is supplied in the multi license Development Packs, it can also be used in data logging applications to upload data or download programs or parameters.

The Module Bus expansion connector is a 68000 bus that allows extra memory and peripherals to be added to the FlashModule controller. The Flash Formatter and the static RAM expansion cards use this expansion bus to interface to the processor. The bus supports A0:23, D0:15 and all the address and data strobes, control lines and four interrupt lines. Also supported on the Module Bus expansion is M-Bus or I<sup>2</sup>C bus. This is a high speed serial bus used for interconnecting a range of peripheral devices. Other products in the FlashModule range use M-Bus devices for the digital I/O and some of the analogue I/O as well as the real time clock that is present on all products in the range. The expansion bus allows the FlashModule products to be used with the many peripherals from our Module Bus range. These include Serial I/O, Video

## FM-600 Embedded CONTROLLER

output, Analogue I/O, Digital I/O, Timer/Counters etc. To ease connection to expansion boards the Module Bus connector is, by default fitted with a DIN41612 connector. Pin strips are available on request.

The FM-600 has a total of 42 digital I/O channels that are fully compatible with CMOS or TTL inputs or outputs. Two of the digital I/O channels are treated as 'specials'. The other forty digital I/O lines can be used either as five 8-bit ports or as individual channels. When used as channels each channel can be configured as an input or an output. If they are configured as outputs, when read, they will return the last value that was written to them. Sixteen of these digital I/O lines can also be used as a matrix keypad interface. The keypad supports most matrix keypads with up to 64 keys on an 8x8 matrix. The user can program the keypad configuration allowing most matrices to be supported. Full Minos driver support is provided for the keypad in the Starter and Development Packs.

The alphanumeric liquid crystal display port allows a range of 2 and 4 line alphanumeric LCDs to be used directly from the

FlashModule. The LCD is mapped into the memory of the FlashModule with full buffering of the data. The FlashModule contains an adjustment for the LCD contrast to obtain the best viewing properties. Using an adapter board a range of graphics LCD panels, using the HD61380 controller, can also be used from the FlashModule. Full Minos driver support is provided for the LCD, which uses a HD44780 compatible controller, in the Starter and Development Packs.

The 8-bit analogue I/O on the FlashModule is provided using some M-Bus peripherals. They give a total of eight channels of analogue input and two channels of 8-bit analogue output. Using the on-board 2.560 Volt reference the full scale input range is between 0.00 and 2.55 Volts. The 8-bit analogue I/O is accurate to within 1 bit or 10mV. The inputs can be software configured for single ended or differential operation. The two analogue outputs are for single ended unipolar output. The 13 bit analogue input also has its own on board reference and can be software programmed for single ended or differential inputs with unipolar or bipolar operation. The

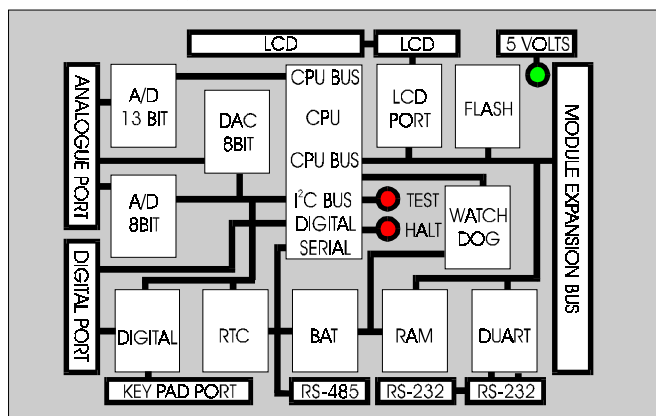

This is a block diagram of the FM-600 Controller.

## ORDER CODES

Order Number	Product Name	1 off	100 off
FM-200	FlashModule FM-200 10 TTL/CMOS Digital I/O	£145	£95
FM-400	FlashModule FM-400 26 TTL/CMOS Digital I/O, LCD, Keypad, 8 Analogue inputs, 2 Analogue outputs	£195	£145
FM-600	FlashModule FM-600 42 TTL/CMOS Digital I/O, LCD, Keypad, 16 Analogue inputs, 2 Analogue outputs	£295	£195
M-100FMS	Modula-2 Starter Pack Single license Minos Modula-2 programming package (including FM-200)	£195	
C-100FMS	C Starter Pack Single license Minos 'C' programming package (including FM-200)	£295	
M-200FM	Modula-2 Development Pack Multi License Minos Modula-2 programming package (including FM-200)	£495	
C-200FM	C Development Pack Multi License Minos 'C' programming package (including FM-200)	£595	

FM600-01 980623



CAMBRIDGE  
MICROPROCESSOR  
SYSTEMS LIMITED

13-bit analogue input can be configured to take up to 32 readings at a time before signalling to the processor that it requires servicing. This is very useful for high speed acquisition, allowing the processor to get on with other tasks leaving the analogue input device to perform its own functions. Full library support is provided for easy access to both the analogue inputs and analogue outputs.

### SOFTWARE DEVELOPMENT

The software development tools for use with the FlashModule products are common across the whole range and use the Minos Real Time Multitasking operating system. Please refer to the separate leaflets on the Development Tools and the Minos Operating System for further details on these powerful tools.

## SPECIFICATION

**CPU.** Motorola 68307 controller, 14.7456 MHz Main clock speed

**Memory.** 512 K-bytes of on board programmable Flash EEPROM, 512 K-bytes of Battery Backed Static RAM, No wait states.

**Serial.** 2 RS-232 Serial Ports, 1 RS-232/RS-485 Serial Port, User selectable baud rates - 300 to 38400, User selectable data size - 5 to 8 bits, User selectable stop characters - 1, 1.5, 2, User selectable parity - odd, even or none, Hardware handshaking on RS-232 ports, Tx and Rx tristates on RS-485.

**Real Time Calendar Clock.** Stores Day, Date and Time, Alarm day, data and time, Accurate to less than 3 seconds per month.

**Digital.** 42 Digital I/O lines, 5 8-bit ports, TTL/CMOS compatible I/O, User configurable.

**Analogue.** 8 13-bit Analogue Inputs, 8 8-bit Analogue Outputs, On board 2.560 Volt reference, User configurable.

**LCD.** Direct drive for wide range of 2 and 4 line LCDs. Adapter required for range of Graphic LCD panels.

**Keypad.** Up to 64 keys on 8x8 matrix, User configurable, Interrupt on keypad.

**Module Bus Expansion.** A0:23, D0:15, 4 Interrupt inputs, 1 non-maskable interrupt input, M-Bus or I<sup>2</sup>C bus interface

**Environmental.** Operating Temperature Range 0 - 70 degC, Relative Humidity 0 to 90% (non condensing)

**Power Supply.** Single 5 Volt operation, Many low power modes, < 250mA typical current consumption



CAMBRIDGE  
MICROPROCESSOR  
SYSTEMS LIMITED

Units 17 - 18 Zone 'D', Chelmsford Road Industrial Estate,  
Great Dunmow, Essex UK CM6 1XG

Telephone +44 (0) 1371 875 644

Fax +44 (0) 1371 876 077

Email sales@cms.uk.com

Web Site <http://www.cms.uk.com>